

West Central District III 2A/3A/4A Girls Volleyball Championships



DATES:

4A Tournament – Friday, November 7th & Saturday, November 15th
3A Tournament – Saturday, November 8th & Saturday, November 15th
2A Tournament – Saturday, November 8th & Saturday, November 15th

LOCATION:

Kitsap Sun Pavilion
1200 Fairgrounds Rd
Bremerton WA 98311

STATE TOURNAMENT / TOYOTA CENTER, KENNEWICK, WA

4A State Tournament – Friday, November 21st & Saturday, November 22nd

3A State Tournament – Thursday, November 20th & Friday, November 21st

2A State Tournament – Friday, November 21st & Saturday, November 22nd

ENTRIES TO STATE:

4A Tournament – six (6) entries

3A Tournament – seven (7) entries

2A Tournament – three (3) entries

TOURNAMENT MANAGEMENT:

Tournament Director: Mark Swofford
North Mason High School
360-277-2165 (Office)
360-277-2224 (FAX)
mwofford@nmsd.wednet.edu

Tournament Manager: Keith Peden
Olympic High School
7070 Stampede Blvd
keithp@cksd.wednet.edu

Tournament Partners: Kitsap County Parks & Recreation
Kitsap County Public Facilities District
Kitsap Sports Council

WEST CENTRAL DISTRICT VOLLEYBALL COMMITTEE:

JoAnne Daughtry, Chair (Kentwood HS), Char Davenport (Lincoln HS), Jerry Peterson (Todd Beamer HS), Gail Barnum (Highline SD), Mark Swofford (North Mason HS), Keith Patefield (Cascade Christian HS), Murray Johnson (Auburn Mountainview HS), Marc Blau (Tacoma Officials Association), Pam Calnan (Olympic/Peninsula Volleyball Officials Association), Wendy Malich (Franklin Pierce SD), and Shelly Thiel (WCD Director)

SPECTATOR ADMISSION:

Per Day:

Adults & Students without ASB.....\$7.00
Students with ASB and Senior Citizens (62+).....\$5.00
Elementary Students (under 12)..... \$4.00
Pre-School (with parents).....No Charge

*Doors open one (1) hour prior to beginning of play

**Remember, the admission prices are per day. Please inform parents of per day prices.

TYPE OF TOURNAMENT:

4A Tournament – sixteen (16) team, double-elimination bracket

3A Tournament – sixteen (16) team, double-elimination bracket

2A Tournament – six (6) team bracket, Games 1 & 2 loser out; Games 3-6 double-elimination.

ALLOCATIONS & ENTRIES TO WCD TOURNAMENT:

| | | |
|----------------|---------------------------------|----|
| 4A Tournament: | South Puget Sound League (SPSL) | 10 |
| | Narrows League (NL) | 6 |

| | | |
|----------------|---------------------------------------|---|
| 3A Tournament: | So Puget Sound/Seamount Leagues (S/S) | 9 |
| | Olympic L./West. Cascade Conf (OWL) | 4 |
| | Greater St. Helens League (SW) | 3 |

| | | |
|----------------|--------------------------------|---|
| 2A Tournament: | Nisqually League (NL) | 3 |
| | Olympic League (OLY) | 3 |
| | *Interlake (KingCo League) | |
| | May earn a spot from NL or OLY | |

ROSTER & ELIGIBILITY:

In order to prepare the tournament program in a timely manner, tournament rosters and team pictures must be submitted on the WIAA website by Friday, October 31st. By submitting a roster and picture at this site, they will be used for both the district and state tournaments. Please submit information ASAP. Changes can be made to district tournament information up to Friday, October 31st. Changes for the state tournament program can be made after this date.



TEAM ENTRY:

All players, coaches and managers must enter together through the “team entry gate” located on the West side of the Pavilion. Only uniformed players and coaches/managers with wrist bands will be allowed to enter through the team gate (4 wrist bands are provided in each team packet). Each team may have a roster of fourteen (14) players and four (4) coaches/managers. Please do not ask for exceptions. Only those listed on the official roster will be allowed on the playing floor or the team bench.

HONORED PASSES:

WCD Executive Board pass, SWD Executive Board pass, SeaKing Executive Board pass and WSCA pass

League, Season, WSSAAA and other passes will not be honored for this event.

PASS GATE & PASS LIST:

The “Pass Gate” will be next to the main entrance to the Pavilion. School Board Members, Administrators and Faculty Supervisors are the only names to be submitted for the pass list.



Administrators and Faculty Supervisors who are on the pass list must be in the vicinity of their student section during matches. Assistance is valuable in maintaining a positive, sportsmanlike atmosphere. Spectators wishing to leave and return for a later match will have their hand stamped.

Your supervision pass list must be faxed or emailed by Monday, November 3rd to:

Mark Swofford

360-277-2224 (FAX)

mwofford@nmsd.wednet.edu

TEAM BUSES & TEAM VANS:

Team buses and vans will enter through the west end parking entrance. Athletes should be dropped off at the west end of the Pavilion. Buses will then proceed straight ahead to the designated bus parking areas. Vans will turn left and park near the President's Hall. Please see site map for details. Only Team buses and vans may park in team parking areas. There are places in the general parking areas for RVs and/or trailers.

SPECTATOR PARKING:

There is parking for nearly 2000 cars surrounding the Kitsap Sun Pavilion. Spectators will enter the "general entry" area at the front of the building. There is no charge for parking.

OFFICIALS & SCORERS:

The Tournament Director will arrange for officials from associations that serve the teams entered in the tournament. Assigning secretaries from each association represented in the tournament, will determine officials to represent their organizations. These officials will serve as game officials, line persons, and scorekeepers. One official will serve as the tournament officials' coordinator.

Libero tracking: If both teams use a libero, the home team will provide a libero tracker at the scorer's table. If only one team uses a libero, that team must supply the libero tracker at the scorer's table.

CHEERLEADERS:

Cheerleaders in uniform will be admitted through the "pass gate". The Tournament Director and officials will determine suitable areas for cheerleaders during matches. For the safety of all involved, cheerleaders must stay within these defined areas during play.

TRAINING ROOMS:

Training room and trainers will be available in the Northwest corner of the Pavilion (near the team entry gate). The training room will be staffed, however, teams should bring their own supplies, such as tape, pre-wrap, etc. Ice is available in the training room and will be provided upon request.

LOCKER ROOMS:

The Pavilion is equipped with 3 small locker rooms. These rooms will be available for teams who are currently playing or are about to play. The primary purpose of the rooms is to provide on-court teams with a semi private restroom, a place to switch libero jerseys, and a place to store one or two team bags which might contain things like players off court shoes, or other items which cannot be left at the team camp. Teams are asked to limit the items to be stored in these areas to just a few "team bags". The rooms will have a volunteer at the entrance, however, the staff is not responsible for theft or loss of items stored in the rooms. There are a few lockers in each room. Teams will need to bring their own locks.

SECURITY:

General site security will be provided by uniformed Navy/Marine Corp/Police personnel. All spectators and participants must follow the directions of security personnel at all times. Spectators and/or participants who refuse to follow reasonable security requests may be removed from the premises and/or subject to arrest.

ATHLETE'S VILLAGE:

An athlete's village will be set up in the President's Hall just behind the Pavilion. The athlete's village will house a warm up area, team camps, and a recreational area. Only athletes, coaches, and team personnel doing team business will be allowed in the athlete's village.

TEAM CAMPS - Each team will have a designated team camp area. These areas will be curtained off and marked. There will also be an attendant to show you where your camp is located. In each area there will be a table and chairs. All coolers, food, and other team items should be limited to these team camp areas. Team bags and other items should be left here and not taken over to the Pavilion as much as possible. There are a few lockers available in the Pavilion prep rooms, in general however, valuables should be left at home. Teams must provide their own locks. Each team is responsible for cleaning up and leaving their area in the same or better condition than they found it. Coolers and outside food are allowed in the presidents hall. However, coolers and outside food are not allowed in the Pavilion. Please ensure parents are aware of this restriction.

WARM-UP AREA - There will be an open area towards the front of the President's Hall that teams may use for general warm up prior to moving over to the Pavilion for their match. This area is suitable for calisthenics, jogging, and light ball handling type activities. This is not an athletic facility. Schools will be charged for any damage caused to the facility. Please ensure that athletes are supervised while warming up. The attendant at the door will have radio communication with the Pavilion so you get over in time. Teams must furnish their own warm-up balls and/or equipment.

RECREATION AREA – There is relatively little “off court” time for teams this year due to the expanded, two weekend schedule. However, we will still have some recreational activities for athletes to participate in and places for athletes to hang out and to meet other athletes. Activities will include things like music, ping pong tables, foos ball, Wii systems, air hockey, etc... There will also be a snack bar where athletes can purchase food and drinks. This area is located in the back of the President's Hall.

FILMING:

There are limited power outlets near the courts. Bring extra batteries. Please be respectful. Spectator seating and viewing takes priority over filming. Owners of cameras which unreasonably block spectator viewing/seating will be asked to move them immediately.

GENERAL INFORMATION:

- Bands are not permitted at this event.
- An official school banner (made of cloth or vinyl) will be the only signs permitted.
- Artificial noisemakers are not permitted and may be confiscated by tournament supervisors or tournament staff.
- The throwing of confetti or other materials is not permitted.
- Outside food will not be allowed in the Pavilion.
- Team camps, spreading out blankets, etc... will not be allowed in the Pavilion.
- **The Tournament Staff reserves the right to make change of courts, times of games, and bench location.**

TOURNAMENT OFFICE:

The tournament office will be located on the first floor near “Crazy Eric's” cafe. Only officials and tournament staff are allowed in the office.

TOURNAMENT HEADQUARTERS:

The tournament headquarters will be located in the upstairs loft above the “general entry” area. Brackets and results will be displayed here. As much as possible, it would be appreciated if questions and issues were first routed through the respective coach to ask the headquarters attendant. If the attendant cannot answer the question he/she will contact the tournament manager or director as soon as possible. Thanks for your help in this regard.

COACHES’ / OFFICIALS’ LOUNGE:

The coaches’ / officials’ lounge is located in the Southwest corner of the Pavilion behind the tournament office. Food, beverages, and places to sit and relax will be provided for referees and coaches only.

RECRUITING:

Invitation letters are being sent to all Western Washington college volleyball staff along with a few outside of Western Washington.

TOURNAMENT T-SHIRTS/CONCESSIONS:

A tournament T-shirt vendor will be located in the upper mezzanine. T-shirts will be made to order. Prices will be determined by the amount of customization done to the shirt. We also plan to have other vendors in the same area such as an athletic apparel/equipment vendor, bake sale, etc...

TOURNAMENT FOOD CONCESSIONS:

Crazy Eric’s café is located near the “general entry” area at the front of the Pavilion. Many items are available for purchase including hamburgers, hotdogs, sausages, fries, onion rings, fruit, soda, etc...

- Water only in the team bench areas
- Café food is allowed in the bleachers

AWARDS:

Championship plaques will be awarded to the Champions and 2nd Place team from each classification (2A, 3A, 4A). In addition individual awards will be awarded to all athletes whose teams make it to the State tournament. These awards will be awarded directly at the conclusion of the deciding match.

TOURNAMENT RULES / REGULATIONS & PROCEDURES

COURT ASSIGNMENTS:

Court assignments will be drawn by the WCD Tournament Committee. The Tournament Director shall have the authority to make adjustments as necessary.

DESIGNATION OF HOME TEAM:

- The home team will be the bottom team on each bracket.
- The home team will warm up first.

PRE-MATCH WARM-UP:

The 5-5-2 warm-up procedure will be followed. The home team warms up first. In an attempt to remain on schedule as much as possible the 5-5-2 will start 15 minutes prior to the published game time OR immediately following the previous match which ever is later. The warm up time will begin whether the teams are there or not. Please be on time. There will be an attendant at the front of the presidents hall with a radio to help you with your timing. However, it is ultimately the responsibility of the coach to get his/her team to the court on time.

TOURNAMENT RULES:

2008 National Federation rules will be used with these exceptions:

- Each match will consist of 3 out of 5 games. First four games to 25 and fifth game to 15 with “no cap”.
- Each school will furnish their own warm-up balls. White match balls will be furnished by the tournament management.
- Game officials, line judges and official scorers will be furnished by the officials’ associations.
- Protests will be ruled on by a protest committee made up of, at a minimum, the tournament director, the supervising referee, and an impartial coach.

WELCOME:

On Behalf of the tournament staff, Kitsap County Parks and Recreation, our sponsors and our many volunteers, we would like to congratulate each an every one of you on a successful season. We welcome you to beautiful Kitsap County and hope that you enjoy your time here. Each team will receive a team packet with this syllabus, coach wristbands, etc... Also look for coupons and other items which our sponsors and community have provided for you. Please do not hesitate to contact any tournament staff member for questions about the area or recommendations. Again, WELCOME and good luck.



Tournament Schedule

| | TIME | GAME #S | COMMENTS |
|----------------------|-------|--------------|----------------------------------|
| FRIDAY 11/7/08 | 2:15 | 1,2,3,4 | 4A ROUND 1 |
| | 4:00 | 5,6,7,8 | 4A ROUND 1 |
| | 5:45 | 9,10,11,12 | 4A ROUND 2 |
| | 7:30 | 13,14,15,16 | 4A ROUND 2 |
| SATURDAY 11/8/08 | 10:00 | 17,18 | 2A ROUND 1 |
| | 11:45 | 19,20,21,22 | 3A ROUND 1 |
| | 1:30 | 23,24,25,26 | 3A ROUND 1 |
| | 3:15 | 27,28,29,30 | 2A/3A ROUND 2 |
| | 5:00 | 31,32,33,34 | 3A ROUND 2 |
| | 6:45 | 35,36 | 3A ROUND 2 |
| SATURDAY 11/15/08 | 10:00 | 37,38,39,40 | 3A LOSER BRACK ROUND 3 |
| | 12:00 | 41,42,43,44 | 4A LOSER BRACK ROUND 3 |
| | 2:00 | 45,46,47,48 | 3A SEMIS & 4TH/5TH GAMES |
| | 4:00 | 49,50,51,52 | 4A SEMIS & 4TH/5TH GAMES |
| | 6:00 | 53,54,56 | 3A PLACING & 2A PLACING |
| | 8:00 | 55, 57,58,59 | 2A/3A/4A CHAMPIONSHIP 4A PLACING |

2A Bracket

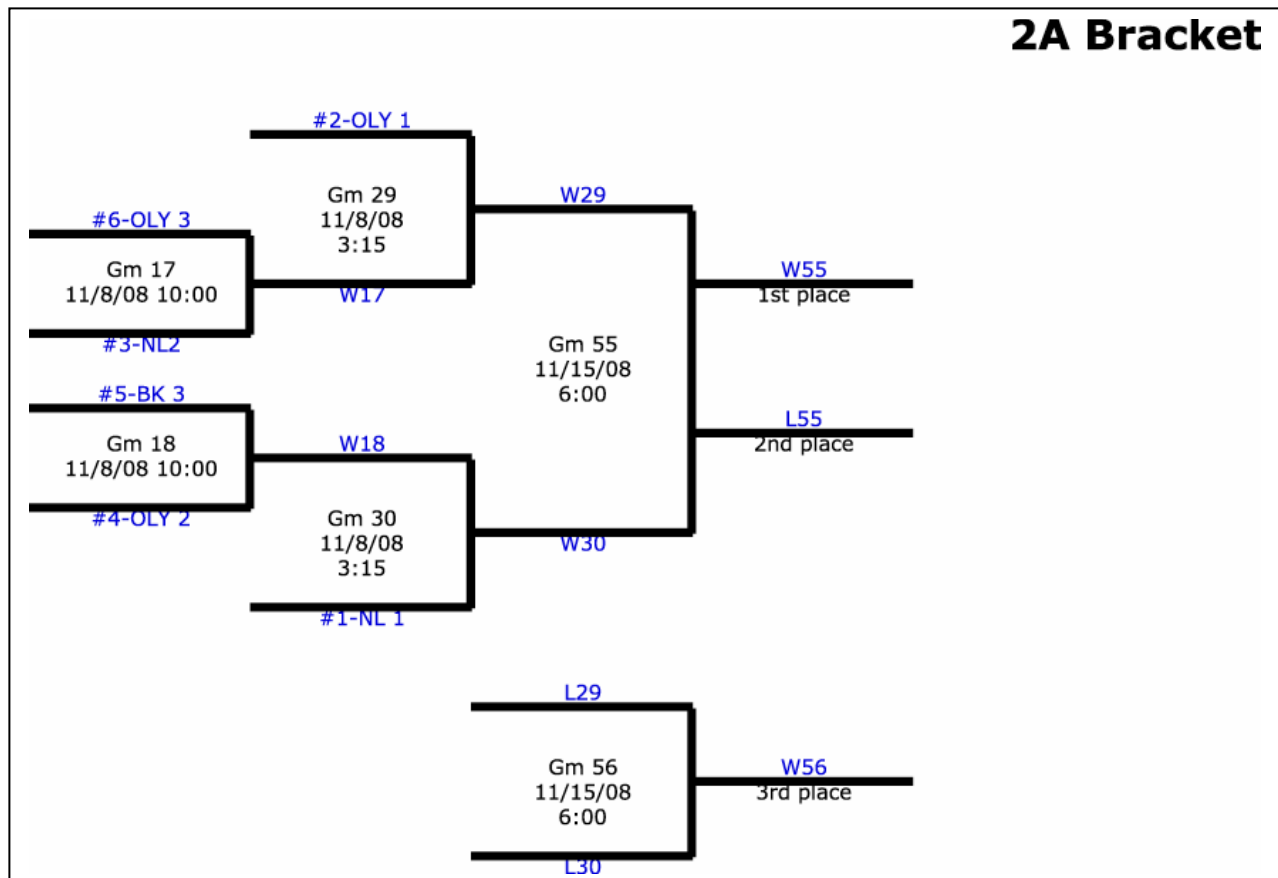

3A Bracket

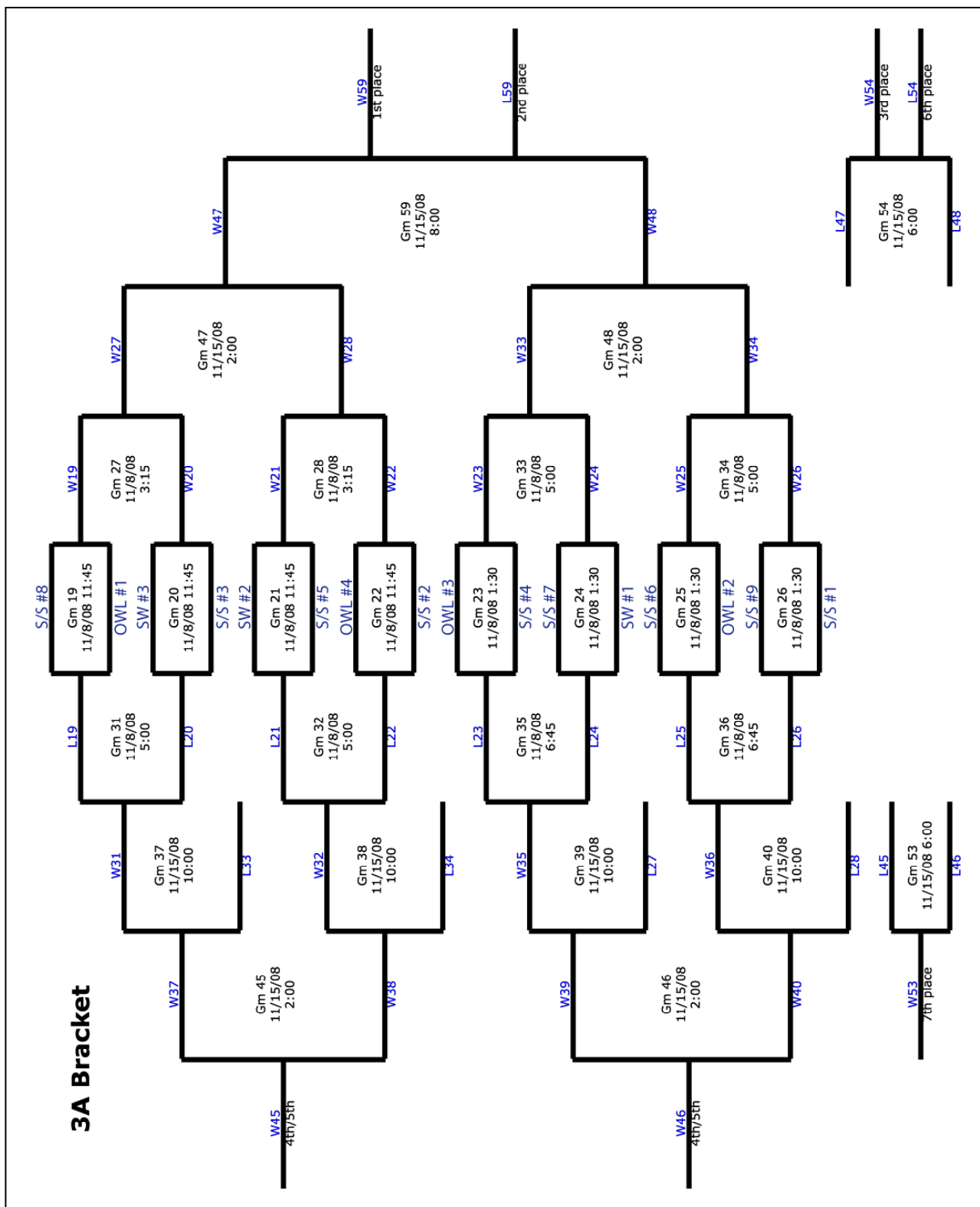

4A Bracket

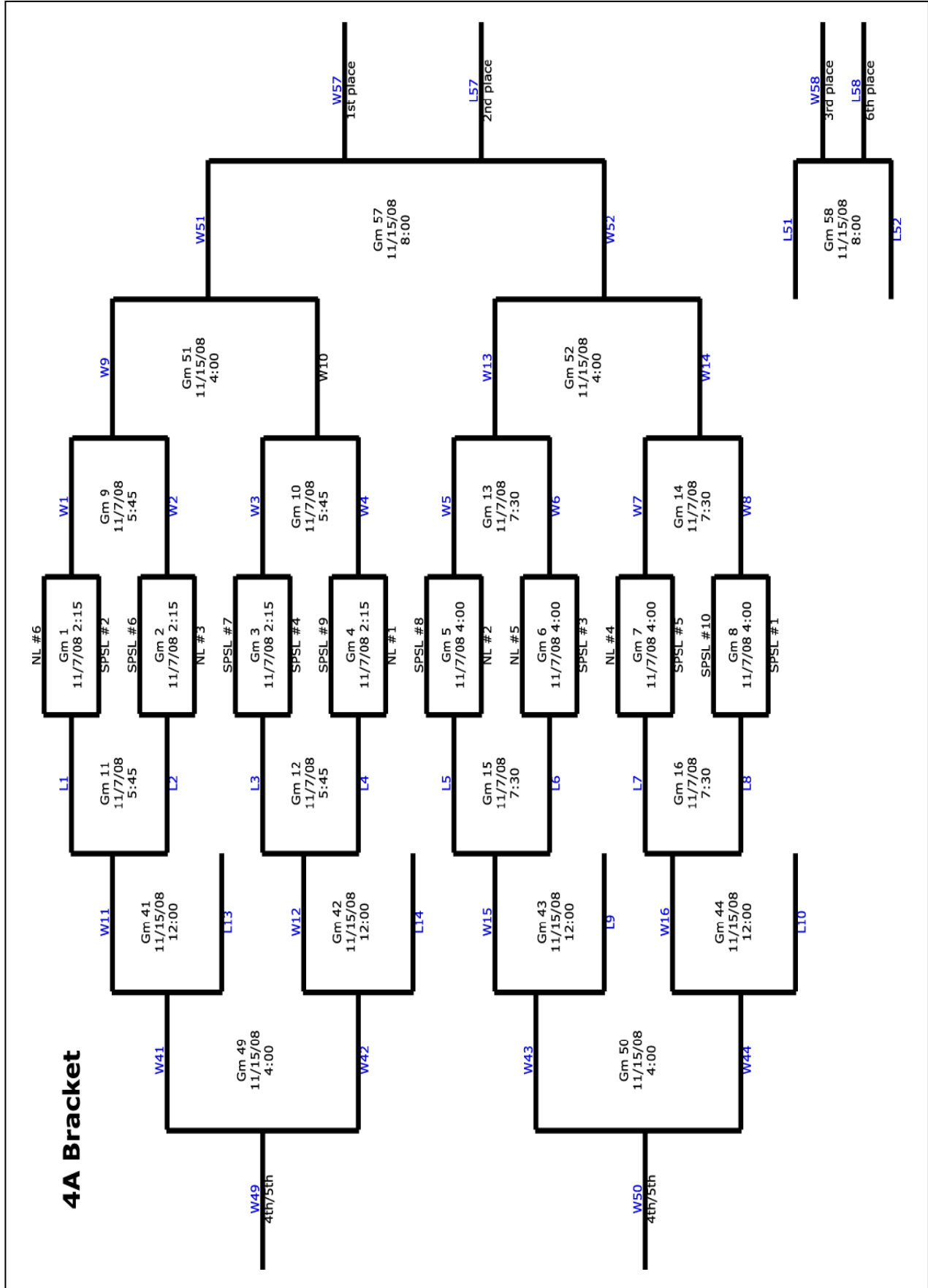

Pavilion - Lower Floor

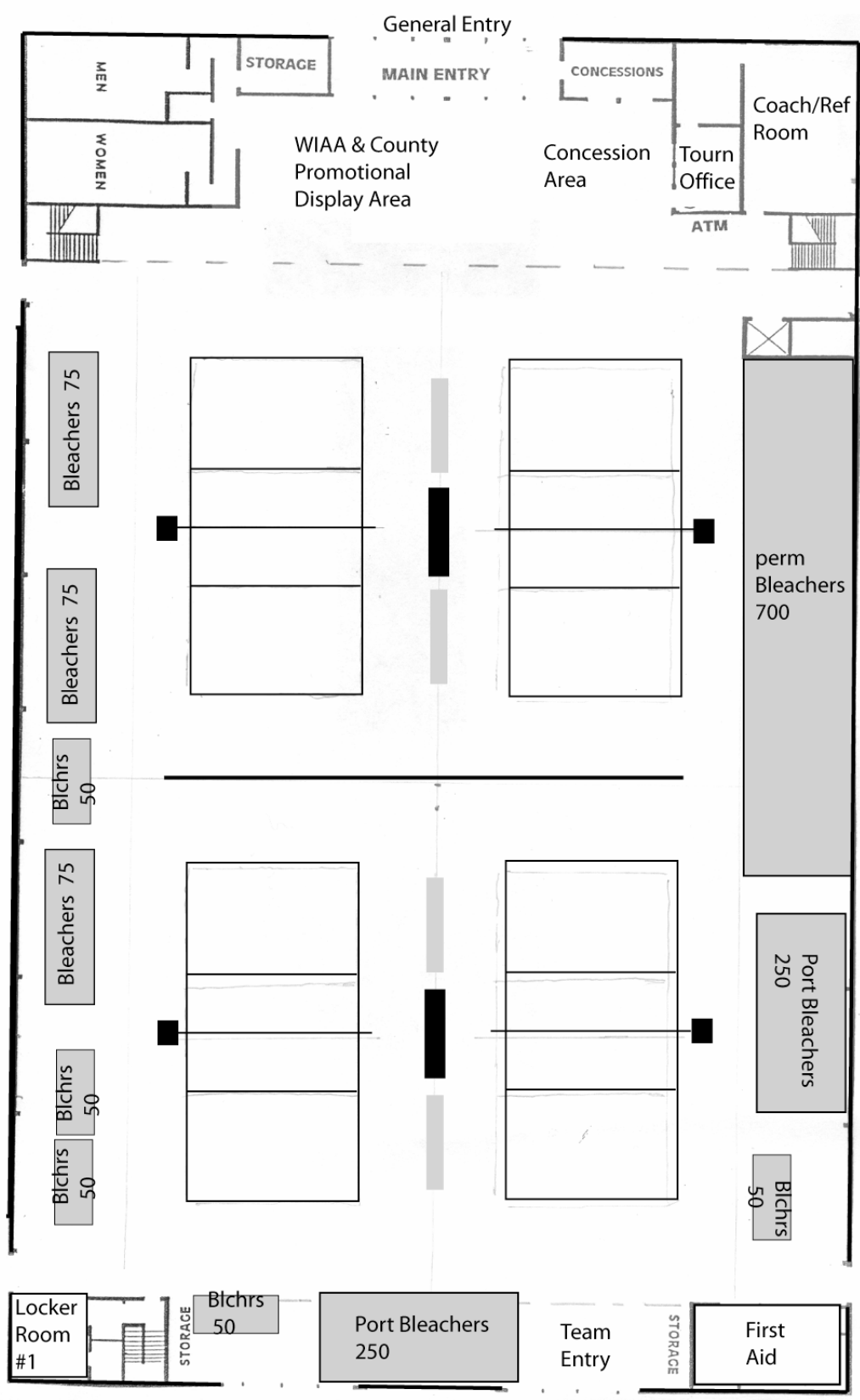

Pavilion - Upper Floor

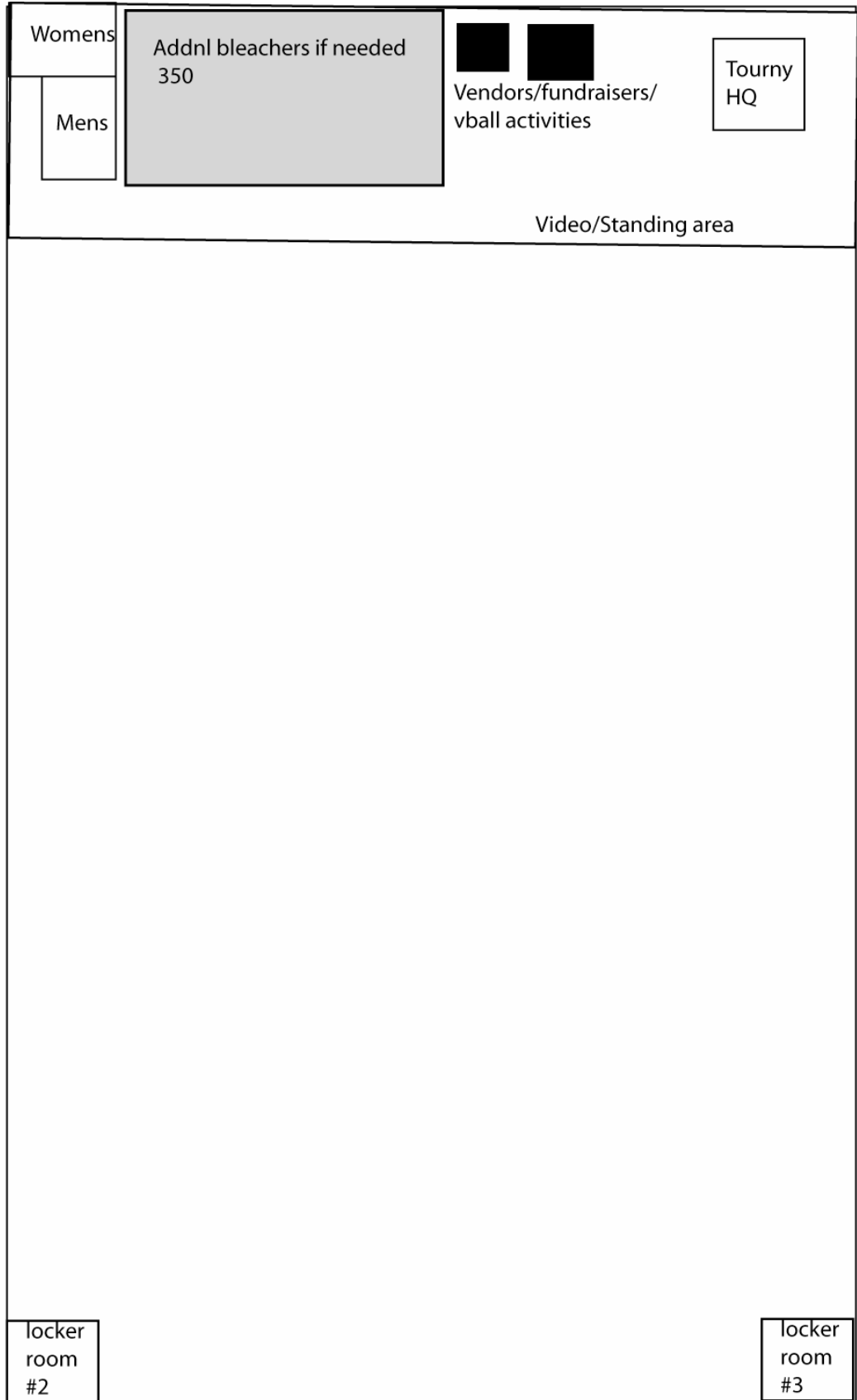

Kitsap County Fairgrounds Site Map

North ↑

